

Ventralizer™

Cathodic Protection

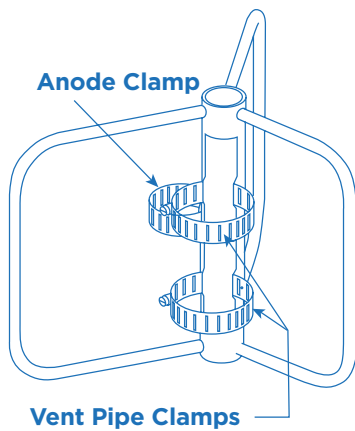

Get The Most Out Of Your Groundbed. Maximize Your Anode Current Output. Minimize Resistance.

The purpose of an impressed current anode in a groundbed is to electronically conduct current to the coke column. In order for this to work, it is critical that the anode be surrounded by well compacted carbonaceous backfill.

In the installation of LIDA® tubular anodes, a common practice is to “tape” the anodes to the vent pipe — feeding a single assembly down the hole. However, this can result in the anode being too close to the vent pipe to allow the backfill to fill around the entire anode surface during pumping operations. To make matters worse, the non-conductive vent pipe can serve to shield portions of the anode in contact with it, resulting in uneven current discharge of the anode.

To attach the LIDA® tubular anodes to the vent pipe, yet allow sufficient spacing between the anode and vent pipe, engineers at De Nora have developed the Ventralizer™.

The Ventralizer's™ dual function is to centralize the anode in the hole, and at the same time, provide 1” of separation between the anode and the vent pipe.

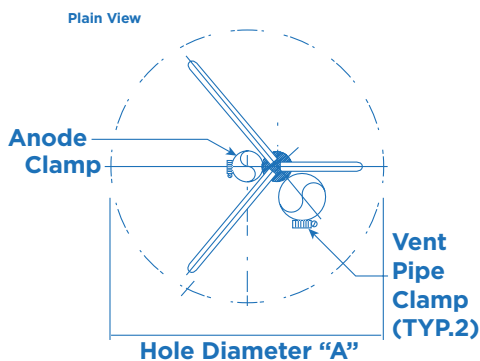

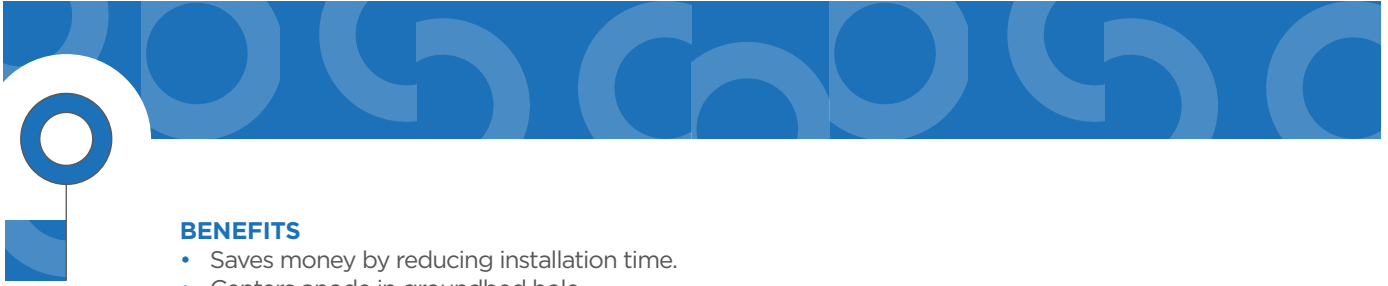

BENEFITS

- Saves money by reducing installation time.
- Centers anode in groundbed hole.
- Maintains proper spacing between anode and non-conductive vent pipe.
- Increases anode lifetime by ensuring backfill coverage on total anode surface area.
- Solid, sturdy construction prevents bending or breakage during installation.
- Smooth, round surfaces guide anode and vent pipe down the hole.

INSTALLATION

- The vent pipe is secured to the Ventralizer™ with two hose clamps. The other clamp should be attached to the anode — only on the copper collars.
- A cordless drill or screwdriver quickly tightens clamps around both the vent pipe and the anode.
- The entire anode and vent pipe assembly can then be easily fed down the groundbed hole.
- On longer anodes, it is recommended that two Ventralizers™ be used — at the top and bottom of the anode.
- On double tail strings, or LIDA® One anodes, the cables from lower anodes should be taped to one of the Ventralizer arms to keep the cable away from the anode.

Dimensions:		
Ventralizer™ Size	Actual Ventralizer™ OD	Recommended Hole Size
4"	3"	3 7/8 to 6"
6"	5"	5 7/8 to 8"
8"	7"	7 7/8 to 10"
10"	9"	9 7/8 to 12"
12"	11"	10 7/8 to 14"



© Copyright 2021 Industrie De Nora S.p.A. - All rights reserved.
De Nora, ON circle, are trademarks or registered trademarks of Industrie De Nora S.p.A. in Europe and/or other countries. Other trademarks used herein are the registered trademarks of their respective owners.
The information contained herein is offered for use by technically qualified personnel at their discretion and risk without warranty of any kind.

marketing@denora.com

www.denora.com

