



CAPITAL CONTROLS® Dry Emergency Gas Scrubber Systems

Engineered to meet national codes for the mitigation of hazardous gas releases from pressurized cylinders to one-ton containers of chlorine and/or sulfur dioxide.

Introduction

Our experience goes back to EST Corporation (EST) in 1983, when EST™ Scrubbers pioneered ejector-venturi technology to wet gas scrubbing, a major innovation which is still unmatched in the industry. In 2003, the portfolio was expanded to include dry scrubber technology. EST products are now marketed under the CAPITAL CONTROLS® brand, the most trusted name in chlorine gas feed since introducing the all-vacuum system in 1960.

Dry scrubbers are safe, user-friendly, low maintenance systems tested and proven for use in municipal and industrial applications where the potential exists for the accidental release of heavier-than-air hazardous gases.

CAPITAL CONTROLS Type DES scrubbers are fabricated from industrial grade Fiberglass-Reinforced Plastic (FRP) to provide corrosion resistance over many years of operation and exposure to harsh weather conditions.



Features and Benefits:

- No Chemical Handling or Maintenance
- Media is Non-hazardous
- One Moving Part - Fan
- No Pumps
- No Leak Containment Required
- No Delay on Start-up
- Dependable Operation
- Tested and Certified to Maximum Leak Rate
- Low Cost of Ownership
- No heaters required in cold climates

Available upon request:

- CAD Drawings
- Sample Specifications
- Media SDS Sheets
- Performance Test Code Certifications
- On-site Room Audits
- Custom Designs



CAPITAL CONTROLS® DES Series Dry Emergency Scrubber

Dry Emergency Scrubber (DES) Series is designed to scrub a leak from an overfilled one-ton portable tank in accordance with the Uniform Fire Code worst-case release of hazardous gas through a fusible plug. The DES3000 system has a room exhaust rate of 3000 cubic feet per minute. The leak from a one-ton portable chlorine container could reach an initial 2400 cfm peak rate. The 3000 cfm scrubber exhaust rate assures a negative pressure on the room, resulting in fugitive gas containment. The system will provide a 1-1/2" w.c. draft available for duct losses of 500 equivalent feet of duct. When sulfur dioxide is present and needs to be scrubbed either alone or in conjunction with chlorine, the bifunctional Type "PHD" chemical media will be used. The "STS" media is considered when chlorine is the lone contaminant gas present.

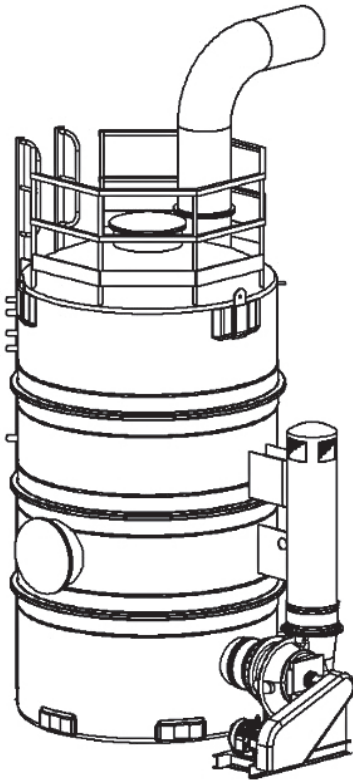

DES3000

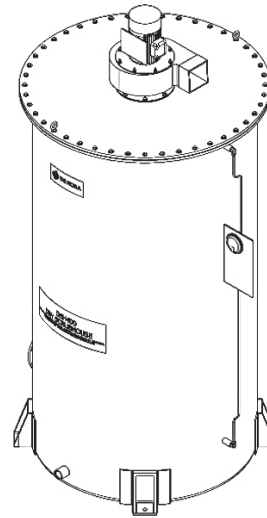

DES400

For 150-pound cylinders normally stored in small rooms or FRP shelters, the DES400 is designed to scrub a leak from two (2) 150-pound cylinders or 300 lbs. of hazardous gas at a leak rate in accordance with Uniform Fire Code requirements while constantly maintaining a negative pressure on the cylinder storage room. The DES400 is designed to treat a chlorine release at a room exhaust rate of 400 cubic feet per minute. The fusible plug gaseous leak from a 150-pound chlorine cylinder could reach an initial 115 cfm peak rate. The scrubber exhaust rate assures a negative pressure on the room and fugitive gas containment.

Size†	Dimensions				Weight (lbs)*	Horsepower
	D Diameter	H Height	A Inlet (Ø)	B Outlet (Ø)		
400	4'	8'8"	6"	5"	900	1
3000	8'	15'11"	18"	24"	3000	20

Notes:

† The size number indicates the scrubber fresh air exhaust rate in cfm.

* Weight is based on an empty single fan system.

CAPITAL CONTROLS® DLP Series Dry Emergency Scrubber

The Dry Low Profile (DLP) Series is designed to scrub a leak from an overfilled one-ton chlorine container in accordance with the Uniform Fire Code worst-case release of hazardous gas through a fusible plug. The chlorine laden gas will be drawn at the top of the tank, pass through the dry media where the gas will be absorbed by the media bed. The Type DLP has a room exhaust rate of 4000 cubic feet per minute. The chlorine leak from the fusible plug can be 2400 scfm. The 4000 cfm scrubber exhaust rate assures a negative pressure in the room for clean air flushing, resulting in fugitive gas containment. The time to pull down the gas volume of the room to 1 ppm after the cessation of the chlorine release is approximately 30 minutes per 10,000 cubic feet of room volume.

The DLP is designed to replace horizontal cross-flow wet scrubbers at an installed cost less than the conversion of an existing wet scrubber.

The bi-functional chlorine/sulfur dioxide scrubbing media Type "PHD" or the chlorine specific "STS" media will be used depending on the gases needed to be scrubbed.

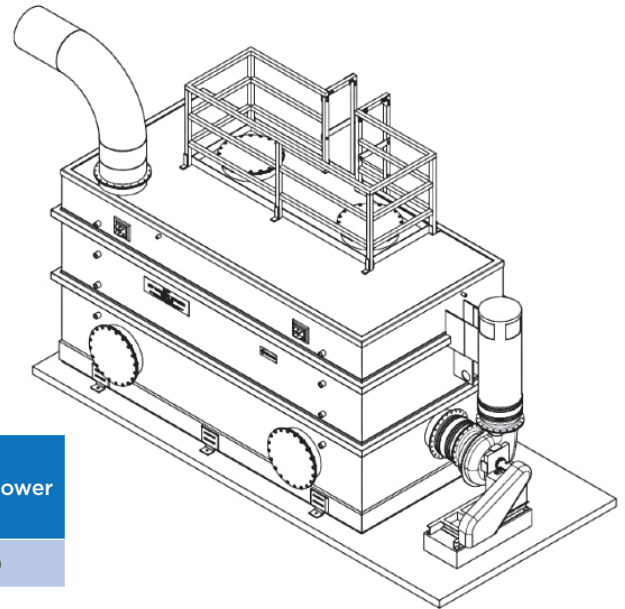

Size†	Dimensions					Weight (lbs)*	Horsepower
	L	W	H	A Inlet (Ø)	B Outlet (Ø)		
4000	18'	7'	8'10"	20"	18"	3600	20

Notes:

† The size number indicates the scrubber fresh air exhaust rate in cfm.

* Weight is based on an empty single fan system without skid.



About De Nora

Backed by 100 years of experience, you can be confident in the reliability and safety of Capital Controls® Scrubbers. De Nora is the partner-of-choice for communities and companies around the globe. In fact, more than 500 million people around the world drink water treated by De Nora products every single day.

info.dnwt@denora.com

www.denora.com

