



# CAPITAL CONTROLS®

## Wet Emergency Gas Scrubber Systems

**Engineered to meet national codes for the mitigation of hazardous gas releases from pressurized cylinders to one-ton containers of chlorine and/or sulfur dioxide.**

### Introduction

Our experience goes back to EST Corporation (EST) in 1983, when EST™ Scrubbers pioneered ejector-venturi technology to wet gas scrubbing, a major innovation which is still unmatched in the industry. In 2003, the portfolio was expanded to include dry scrubber technology. EST products are now marketed under the CAPITAL CONTROLS® brand, the most trusted name in chlorine gas feed since introducing the all vacuum system in 1960.

Wet emergency scrubbers use caustic to neutralize the chlorine gas. CAPITAL CONTROLS multi-stage wet scrubber designs use ejector venturis and packed towers. This innovative design has only one moving part, the caustic pump. The ejector-venturi begins to scrub immediately on start-up, there is no delay that allows unscrubbed chlorine gas to escape.

And our multi-venturi design is packless, using six ejector-venturis in series to neutralize the chlorine gas. Standard and low-profile versions are available.

### Features and Benefits:

- No Start-up Delay
- Venturi-driven; Maximize Gas Transfer
- Multi-stage Design
- No Packing Material to Foul (opt.)
- Tested and Certified to Maximum Leak Rate



## CAPITAL CONTROLS® EPT Series Emergency Gas Scrubber

The Ejector-venturi Packed Tower (EPT) Series is applied throughout industry for the absorption of various gases including chlorine. Fans are not required as the highly reliable ejector-venturi scrubber entrains the contaminated gas and causes air movement through the system. The first stage venturi is well suited to handle the high initial concentrations of chlorine gas. After the gas exits the venturi, the caustic is disengaged and contained within the separator. The gas then passes through the packed tower where the chlorine concentration is reduced to a level below that required by the prevailing codes. A recirculation pump supplies the required caustic solution to the ejector-venturi scrubber and the packed tower.

De Nora Water Technologies has full scale tested the system for a 2000 pound chlorine release at a rate of 425 lb/min with a full 3000 cfm scrubber exhaust rate. The chlorine concentration at the exit of the system did not exceed 0.3 ppm at any time during the test.

The flow of liquid and gas is both co-current and counter-current with a liquid rate to each stage matched to absorption performance. This precludes the possibility of caustic starvation. The system has the capability to handle the worst-case release rate of liquid chlorine based on total vaporization of the chlorine.

The EPT 3000 and 5000 are designed to neutralize a one ton portable tank with a leak rate of up to 437 lb/min throughout the leak event. An EPT 5000 system is normally considered only when the gas capacity needs to be split between two or more rooms or if a single room volume exceeds 50000 cubic feet.

For capacities up to 90 ton rail cars, consult De Nora for dimensions, specifications and details of multi-ton wet EPT Series emergency gas scrubbers.

Size†	Dimensions					Weight lbs.*	Horsepower
	L	W	H	A Inlet (Ø)	B Outlet (Ø)		
3000	14'	10'	19'	18"	18"	6000	40
5000	14'	10'	22'	24"	24"	7000	60

\* Weight is based on an empty two pump EPT System.

† Size numbers indicate the scrubber air exhaust rate in cfm.

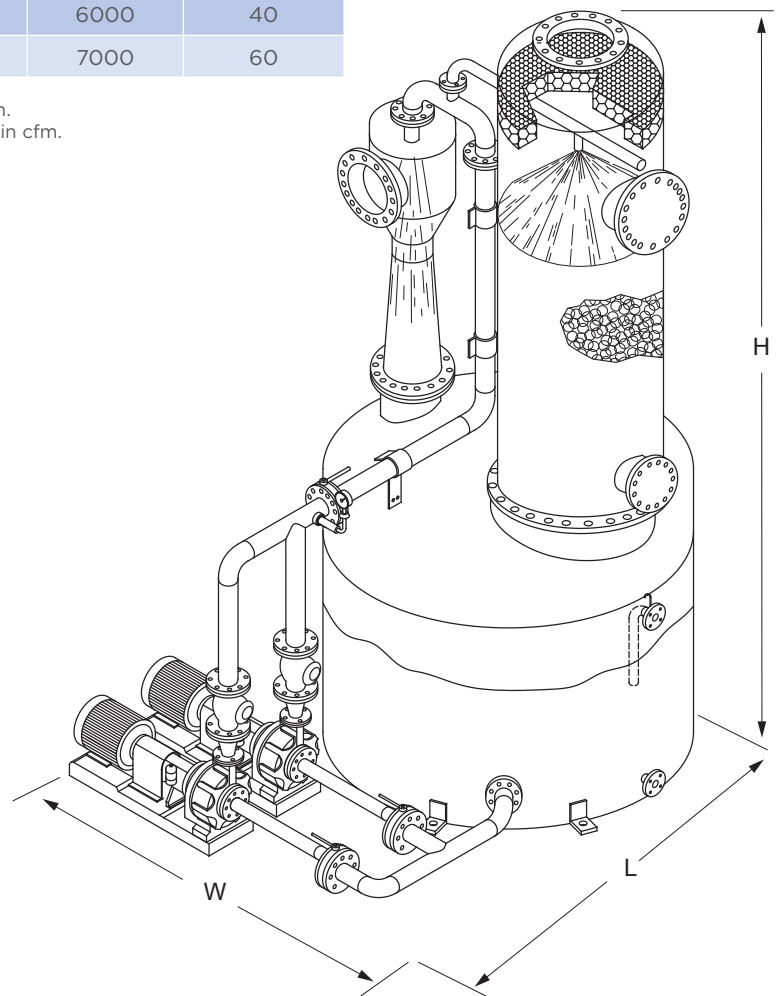

## CAPITAL CONTROLS® MVP Series Emergency Gas Scrubber

At only 8' tall, the fan-driven Multi Venturi Packless (MVP) scrubber is De Nora Water Technologies' lowest profile emergency chlorine scrubber. The fan-driven system consists of six venturis in series with a downstream fan which keeps the entire scrubber system under a negative pressure. Even with fan failure, the venturis will provide a system capacity of about 2/3 of the rated capacity, or 2000 cfm for a 3000 cfm system.

The MVP is a low total horsepower system with a low liquid caustic pressure. Liquid and gas flow are co-current with a liquid rate to each stage matched to absorption performance, so there is no possibility of caustic starvation.

The caustic solution is supplied to each of the six venturi stages by a vertical seal-less recirculation pump. The system is available with either one or two pumps.

Advantages of the system include the capability to handle the worst-case release rate of liquid chlorine based on total vaporization of the chlorine. The chlorine concentration at the exit of the system is reduced to a level below that required by the prevailing fire codes. Since there is no packing in the system, less surface area is available for carbonate buildup during down periods. Therefore, a longer caustic solution service life is expected.

The MVP 3000 and 5000 are designed to neutralize a one-ton chlorine portable tank at a leak rate of up to 437 lb/min throughout the leak event.

Size†	Dimensions					Weight lbs.*	Horsepower	
	L	W	H	A Inlet (Ø)	B Outlet (Ø)		Pump	Fan
3000	13'	7'	8'	18"	18"	4500	20	5
5000	15'	8'	10'6"	24"	24"	6500	25	7.5

\* Weight is based on an empty two pump MVP System.

† Model numbers indicate the scrubber air exhaust rate in cfm.

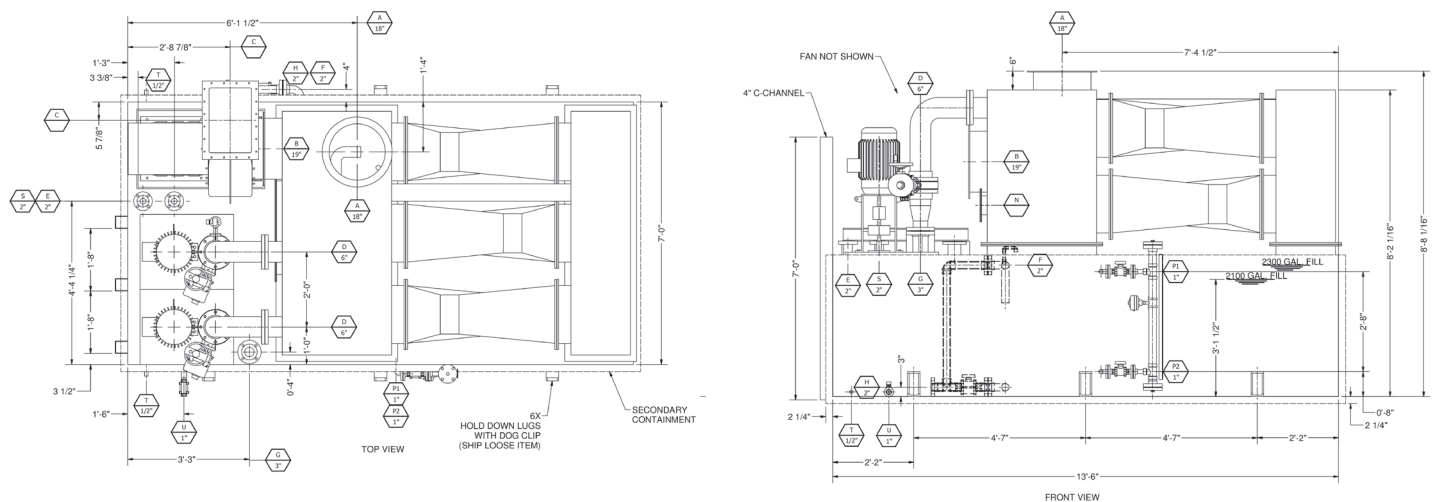



## CAPITAL CONTROLS® SWS Series Emergency Gas Scrubber

The SideWinder (SWS) is a low profile version of the proven Wet Emergency Chlorine Scrubber. To reduce height, the venturi is laid on its side and the packed tower is divided into three shorter towers. The towers and venturi are mounted on a rectangular caustic storage tank, thus reducing the total height of the SWS to about half that of the EPT. The caustic required for neutralization of the chlorine is contained within the lower section of the tank. A vertical seal-less recirculation pump supplies caustic solution to the ejector-venturi scrubber and packed towers. System configurations include either one or two pumps to provide for redundancy of moving parts. Performance of the system is essentially identical to that of the EPT.

Advantages of the system include a low profile, co-current and counter-current flow design. The liquid rate to each contactor is matched to the absorption performance, so there is no possibility of caustic starvation. Like the EPT, the SideWinder has the capability to handle the worst-case release rate of liquid chlorine based on total vaporization of the chlorine while lowering the outlet chlorine concentration to below the level required by the prevailing codes.

For capacities 2 to 8 ton, consult De Nora for dimensions, specifications and details of multi-ton wet SWS Series emergency gas scrubbers.

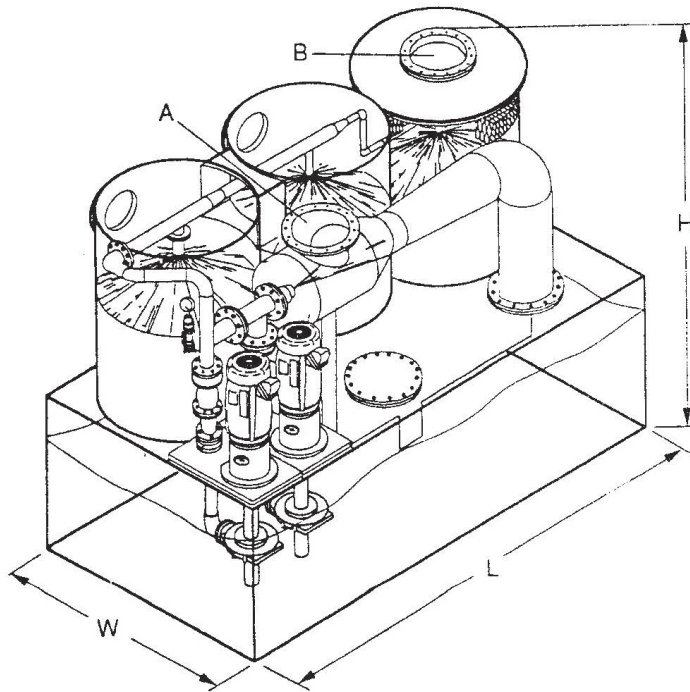

## About De Nora

Backed by 100 years of experience, you can be confident in the reliability and safety of Capital Controls® Scrubbers. De Nora is the partner-of-choice for communities and companies around the globe. In fact, more than 500 million people around the world drink water treated by De Nora products every single day.

[info.dnwt@denora.com](mailto:info.dnwt@denora.com)

[www.denora.com](http://www.denora.com)

